

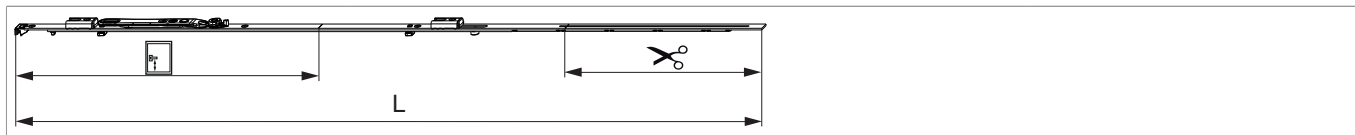

221905 - MM Stulpflügelgetriebe fix Beschlagsnut EH 1340 für 2 i.S. GM 500 FFH 1.091-1.340 silber

Technische Zeichnung



				L				№
Silber	für 2 i.S.	1340	500	1.236,5	1.091 - 1.340	260,5	10	221905 ¹⁾

¹⁾ Für einbruchhemmende Fenster nach EN 1627.

Schraubpositionstabelle

№		1	2	3	4	5	6	7	8	9
221905	7	18,5	91,5	303,5	400	628,5	674	845		

Stanzbild

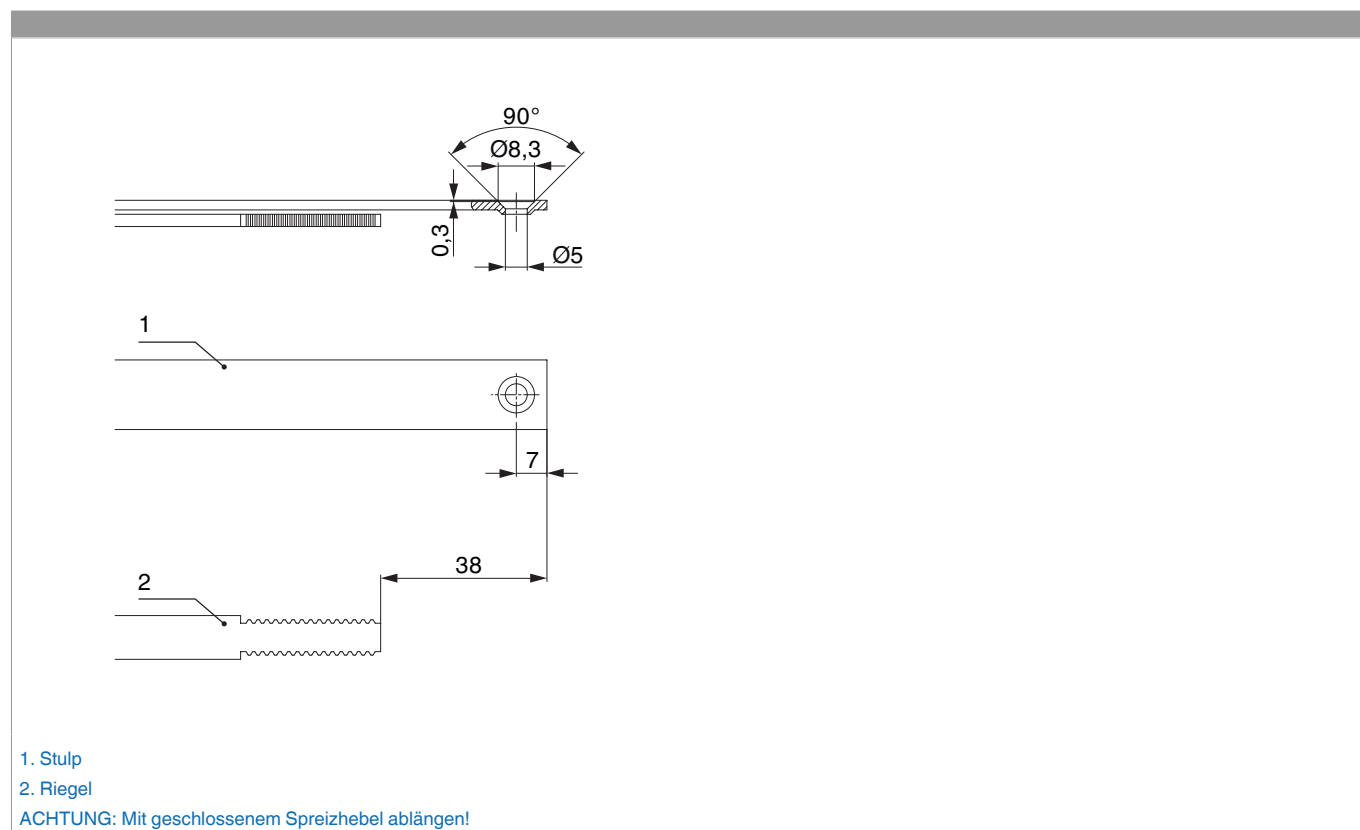



221905 - MM Stulpflügelgetriebe fix Beschlagsnut EH 1340 für 2 i.S. GM 500 FFH 1.091-1.340 silber

Klipsverbindung

Klipsverbindung einhängen

1

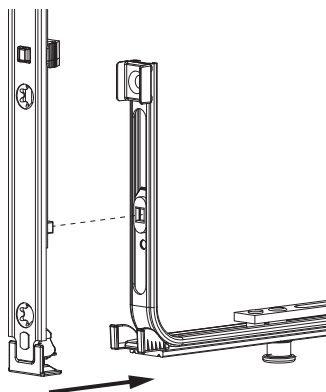

2

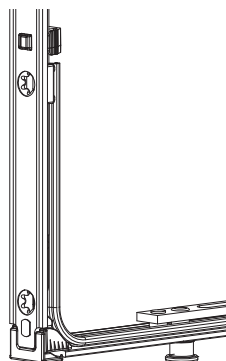

Klipsverbindung aushängen

1

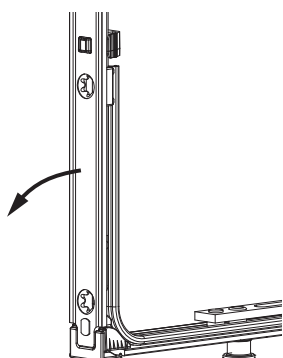

2

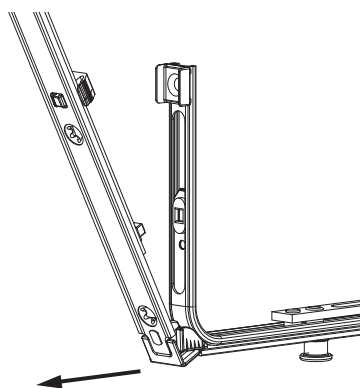

3

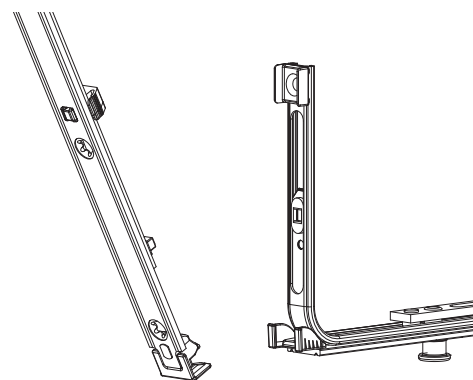



221905 - MM Stulpflügelgetriebe fix Beschlagsnut EH 1340 für 2 i.S. GM 500 FFH 1.091-1.340 silber

Zahnkassenverbindung

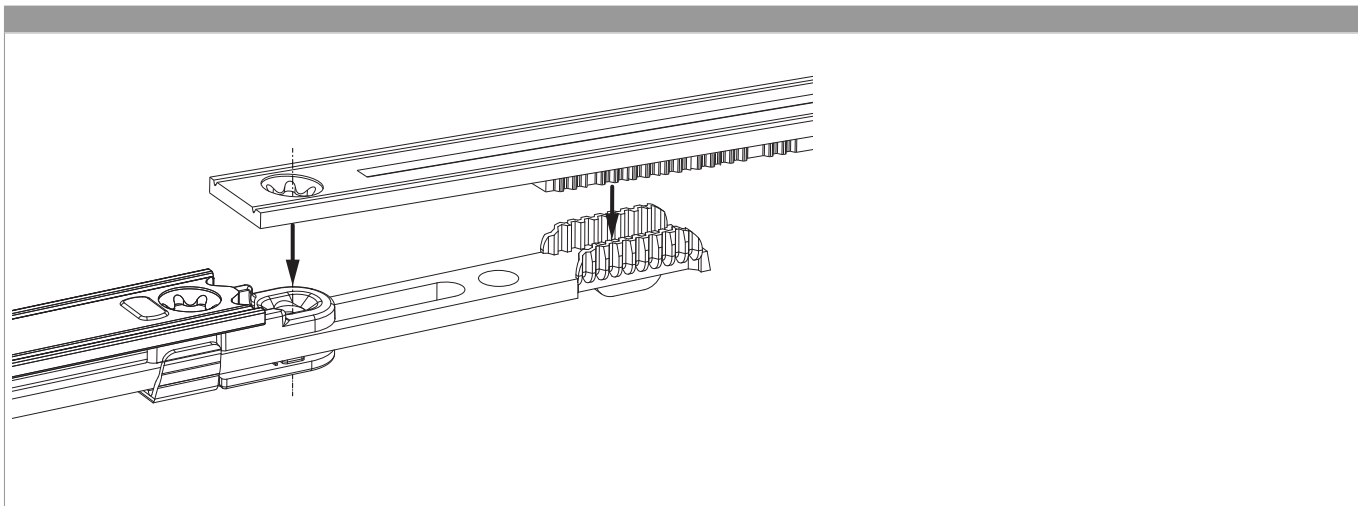

Montage

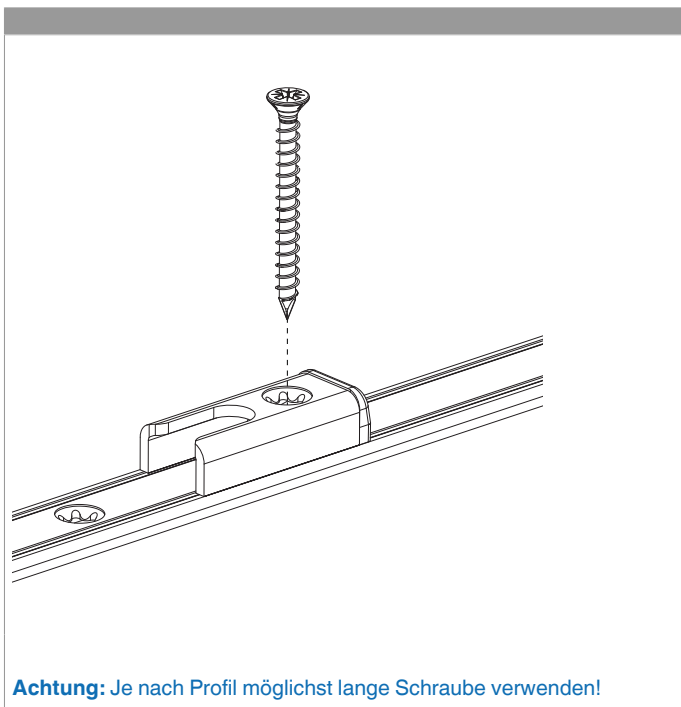



221905 - MM Stulpflügelgetriebe fix Beschlagsnut EH
1340 für 2 i.S. GM 500 FFH 1.091-1.340 silber

Gegenüberstellung der Kerbmarken

