

## 221909 - MM Stulpflügelgetriebe fix Beschlagsnut 2450 für 4 i.S. GM 1.050 FFH 2.201-2.450 silber

### Technische Zeichnung

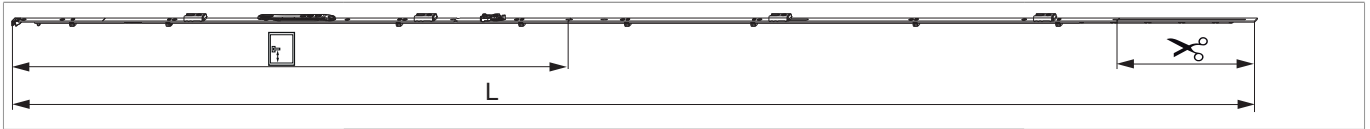

Silber	für 4 i.S.	2450	1.050	L	2.201 - 2.450	260,5	10	221909											

### Schraubpositionstabelle

No	1	2	3	4	5	6	7	8	9	10	11	12	13	14	15	16	
221909	16	18,5	91,5	303,5	350	477	630	738,5	784,5	896	950	1.150	1.409	1.455	1.695	1.909	1.955

### Stanzbild

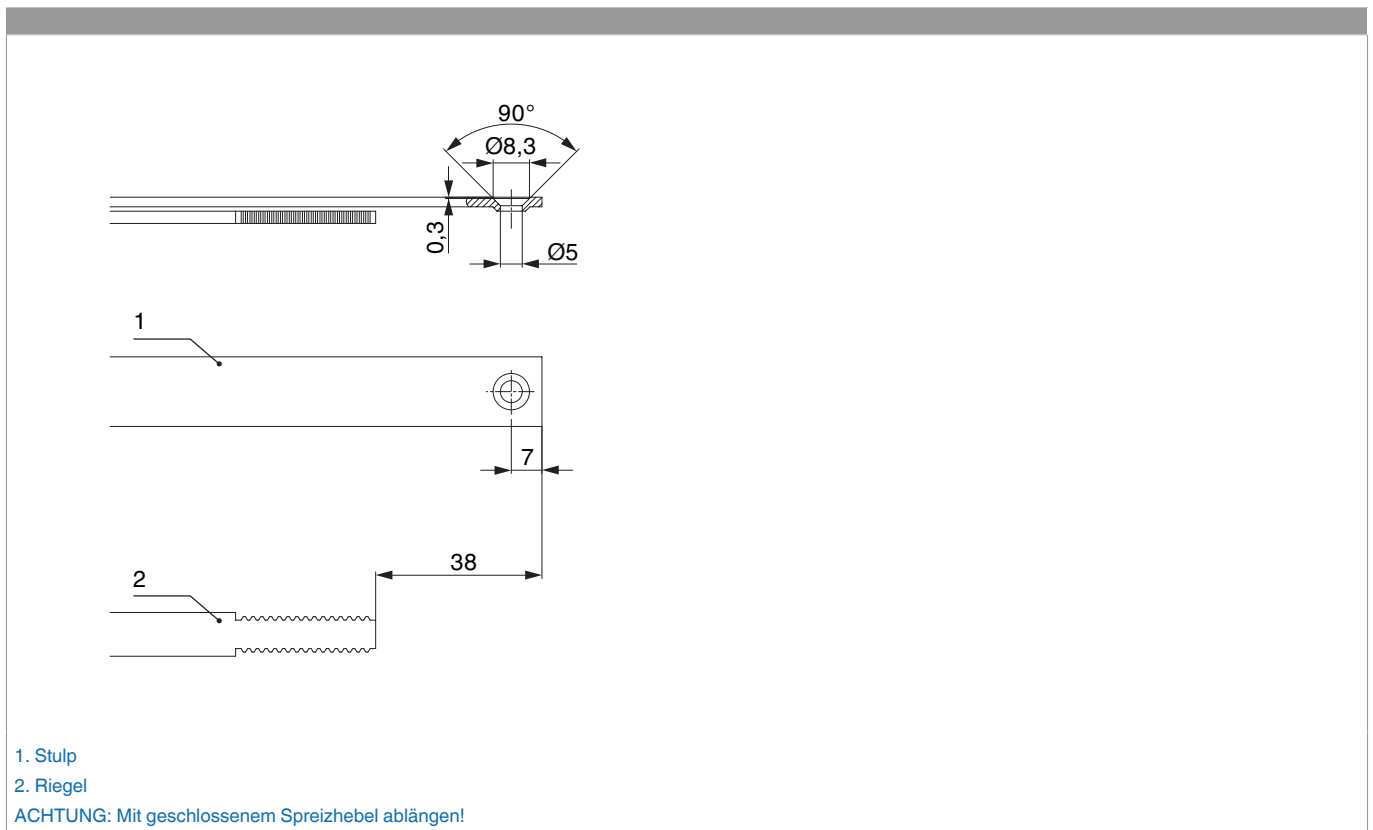



221909 - MM Stulpflügelgetriebe fix Beschlagsnut 2450  
für 4 i.S. GM 1.050 FFH 2.201-2.450 silber

### Klipsverbindung

#### Klipsverbindung einhängen

①

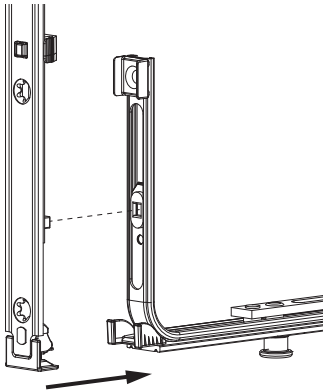

②

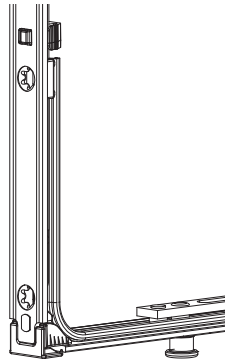

#### Klipsverbindung aushängen

①

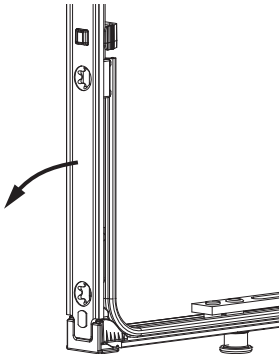

②

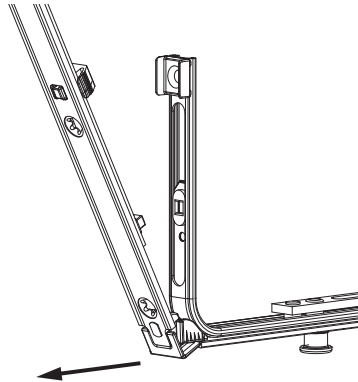

③

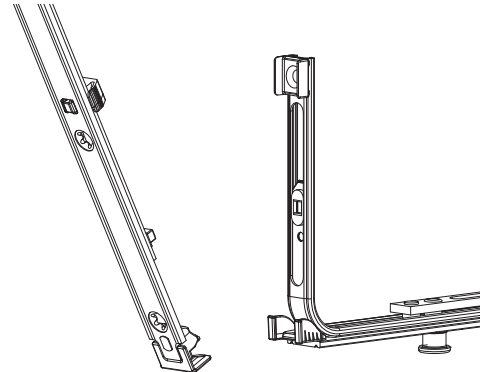



## 221909 - MM Stulpflügelgetriebe fix Beschlagsnut 2450 für 4 i.S. GM 1.050 FFH 2.201-2.450 silber

### Zahnkassenverbindung

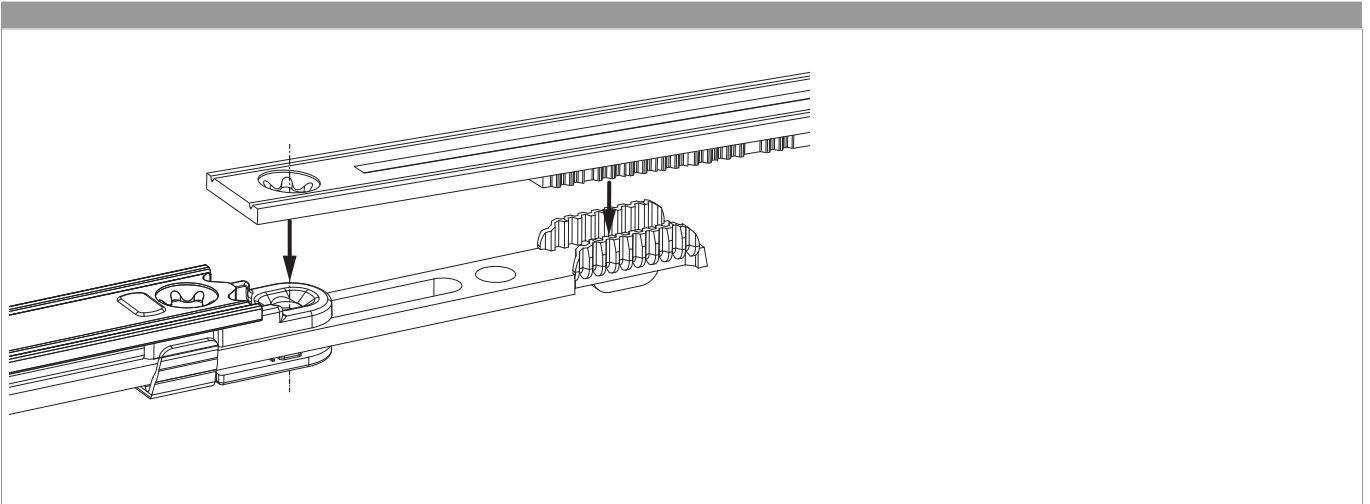

### Montage

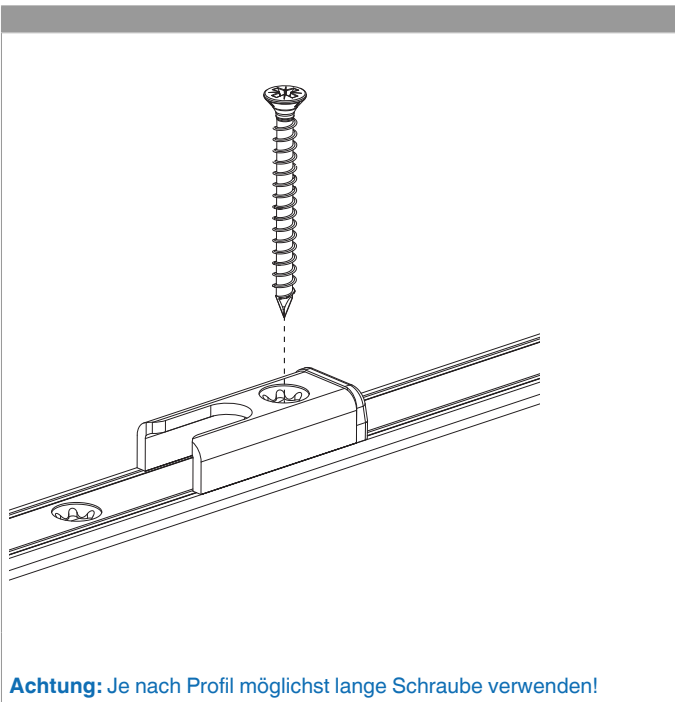



221909 - MM Stulpflügelgetriebe fix Beschlagsnut 2450  
für 4 i.S. GM 1.050 FFH 2.201-2.450 silber

Gegenüberstellung der Kerbmarken

